

Dielectrics and Ferroelectrics

- **Macroscopic Electric Field in a Material**
- **Local Electric Field at an Atom**
- **Dielectric Constant**
- **Structural Phase Transitions**
- **Ferroelectric Crystals**
- **Displacive Transitions**
- **Piezoelectricity**

Macroscopic Electric Field in a Material

We first want to ask two questions:

- What is the relation in the material between the dielectric polarization \mathbf{P} and the macroscopic electric field \mathbf{E} in the Maxwell equations?
- What is the relation between the dielectric polarization and the local electric field which acts at the site of an atom in the lattice? The local field determines the dipole moment of the atom.

Maxwell Equations (in CGS)

$$\text{curl } \mathbf{H} = \frac{4\pi}{c} \mathbf{j} + \frac{1}{c} \frac{\partial}{\partial t} (\mathbf{E} + 4\pi\mathbf{P}) ;$$

$$\text{curl } \mathbf{E} = -\frac{1}{c} \frac{\partial \mathbf{B}}{\partial t} ;$$

$$\text{div } \mathbf{E} = 4\pi\rho ;$$

$$\text{div } \mathbf{B} = 0 ;$$

Polarization

The *polarization* \mathbf{P} is defined as the *dipole moment per unit volume*, averaged over the volume of a cell. The total dipole moment is defined as $\mathbf{p} = \sum q_n \mathbf{r}_n$, where \mathbf{r}_n is the position vector of the charge q_n .

The electric field at a point \mathbf{r} from a dipole moment \mathbf{p} is given by a standard result of elementary electrostatics:

$$\mathbf{E}(\mathbf{r}) = \frac{3(\mathbf{p} \cdot \mathbf{r})\mathbf{r} - r^2\mathbf{p}}{r^5}$$

The lines of force of a dipole pointing along the z axis are shown in the right.

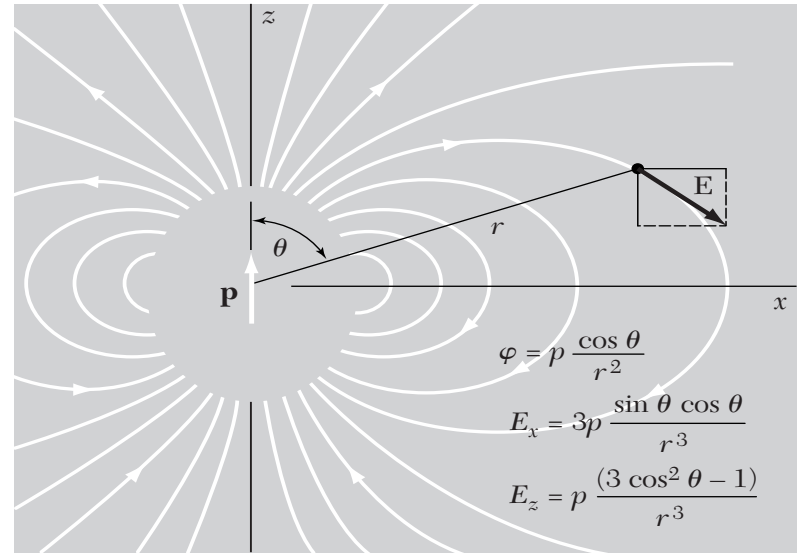

We define the *macroscopic electric field* $\mathbf{E}(\mathbf{r}_0)$ as the average field over the volume of the crystal cell that contains the lattice point \mathbf{r}_0 :

$$\mathbf{E}(\mathbf{r}_0) = \frac{1}{V_c} \int dV \mathbf{e}(\mathbf{r}) \quad , \quad \text{where } \mathbf{e}(\mathbf{r}) \text{ is the microscopic electric field at the point } \mathbf{r}.$$

It is adequate for all problems in the electrodynamics of crystals provided that we know the connection between \mathbf{E} , the polarization \mathbf{P} , and the current density \mathbf{j} , and provided that the wavelengths of interest are long in comparison with the lattice spacing.

By a famous theorem of electrostatics the macroscopic electric field caused by a uniform polarization \mathbf{P} is equal to the electric field in vacuum of a fictitious surface charge density $\sigma = \hat{\mathbf{n}} \cdot \mathbf{P}$ on the surface of the body. Here $\hat{\mathbf{n}}$ is the unit normal to the surface, drawn outward from the polarized matter.

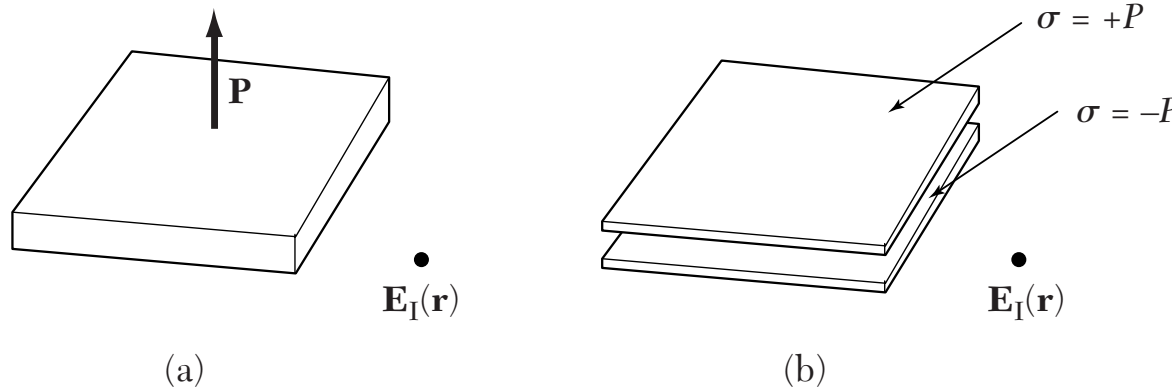

By Gauss's law, $E_1 = -4\pi|\sigma| = -4\pi P$.

We add \mathbf{E}_1 to the external applied field \mathbf{E}_0 to obtain the total macroscopic field \mathbf{E} inside the slab, with $\hat{\mathbf{z}}$ the unit vector normal to the plane of the slab:

$$\mathbf{E} = \mathbf{E}_0 + \mathbf{E}_1 = \mathbf{E}_0 - 4\pi P \hat{\mathbf{z}}$$

If the polarization is uniform within the body, the only contributions to the macroscopic field \mathbf{E} are from \mathbf{E}_0 and \mathbf{E}_1 .

Depolarization Field

The field \mathbf{E}_1 is called the *depolarization field*, for within the body it tends to oppose the external applied field \mathbf{E}_0 as in the figure below. If P_x, P_y, P_z are the components of the polarization \mathbf{P} referred to the principal axes of an ellipsoid, then the components of the depolarization field are written

$$E_{1x} = -N_x P_x ; \quad E_{1y} = -N_y P_y ; \quad E_{1z} = -N_z P_z$$

Here N_x, N_y, N_z are the *depolarization factors*; their values depend on the ratios of the principal axes of the ellipsoid. The N 's are positive and satisfy the sum rule $N_x + N_y + N_z = 4\pi$ in CGS, and $N_x + N_y + N_z = 1$ in SI.

We introduce the *dielectric susceptibility* χ such that polarization $\mathbf{P} = \chi \mathbf{E}$, then

$$E = E_0 + E_1 = E_0 - NP ; \quad P = \chi(E_0 - NP) ; \quad P = \frac{\chi}{1 + N\chi} E_0$$

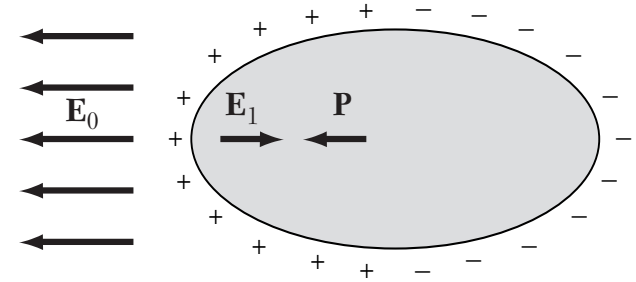

A uniform \mathbf{E}_0 will induce uniform polarization in an ellipsoid.

Shape	Axis	N (CGS)	N (SI)
Sphere	any	$4\pi/3$	$1/3$
Thin slab	normal	4π	1
Thin slab	in plane	0	0
Long circular cylinder	longitudinal	0	0
Long circular cylinder	transverse	2π	$1/2$

Local Electric Field at an Atom

The value of the local electric field that acts at the site of an atom is significantly different from the value of the macroscopic electric field. Consider the field that acts on the atom at the center of the sphere. If all dipoles are parallel to the z axis and have magnitude p , the z component of the field at the center due to all other dipoles is,

$$E_{\text{dipole}} = p \sum_i \frac{3z_i^2 - r_i^2}{r_i^5} = p \sum_i \frac{2z_i^2 - x_i^2 - y_i^2}{r_i^5}$$

The x , y , z directions are equivalent because of the symmetry; thus

$$\sum_i \frac{z_i^2}{r_i^5} = \sum_i \frac{x_i^2}{r_i^5} = \sum_i \frac{y_i^2}{r_i^5}, \text{ whence } E_{\text{dipole}} = 0.$$

The local field at an atom is the sum of the electric field \mathbf{E}_0 from external sources and of the field from the dipoles within the specimen. It is convenient to decompose the dipole field so that part of the summation over dipoles may be replaced by integration. Then,

$$\mathbf{E}_{\text{local}} = \mathbf{E}_0 + \mathbf{E}_1 + \mathbf{E}_2 + \mathbf{E}_3$$

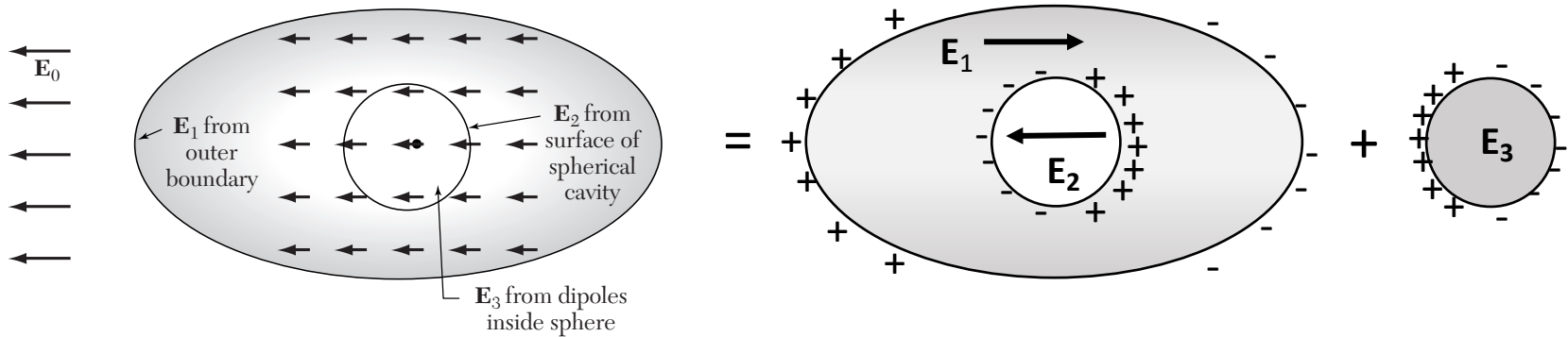

$$\mathbf{E}_{\text{local}} = \mathbf{E}_0 + \mathbf{E}_1 + \mathbf{E}_2 + \mathbf{E}_3$$

$$\mathbf{E}_1 + \mathbf{E}_2 + \mathbf{E}_3 = \sum_i \frac{3(\mathbf{p}_i \cdot \mathbf{r}_i)\mathbf{r}_i - r_i^2 \mathbf{p}_i}{r_i^5}$$

\mathbf{E}_0 = field produced by fixed charges external to the body;

\mathbf{E}_1 = depolarization field, from a surface charge density $\hat{\mathbf{n}} \cdot \mathbf{P}$ on the outer surface of the specimen;

\mathbf{E}_2 = Lorentz cavity field: field from polarization charges on inside of a spherical cavity cut (as a mathematical fiction) out of the specimen with the reference atom as center; $\mathbf{E}_1 + \mathbf{E}_2$ is the field due to uniform polarization of the body in which a hole has been created;

\mathbf{E}_3 = field of atoms inside cavity.

The contribution $\mathbf{E}_1 + \mathbf{E}_2 + \mathbf{E}_3$ to the local field is the total field at one atom caused by the dipole moments of all the other atoms in the specimen.

Lorentz Cavity Field

The field \mathbf{E}_2 due to the polarization charges on the surface of the fictitious cavity was calculated by Lorentz. If θ is the polar angle referred to the polarization direction, the surface charge density on the surface of the cavity is $-P \cos\theta$. The electric field at the center of the spherical cavity of radius a is

$$\mathbf{E}_2 = \int_0^\pi (a^{-2})(2\pi a \sin \theta)(a d\theta)(\mathbf{P} \cos \theta)(\cos \theta) = \frac{4\pi}{3}\mathbf{P}$$

The field \mathbf{E}_3 due to the dipoles within the spherical cavity is the only term that depends on the crystal structure. For a reference site with cubic surroundings in a sphere that $\mathbf{E}_3 = 0$ if all the atoms may be replaced by point dipoles parallel to each other. The total local field at a cubic site is, $\mathbf{E}_{\text{local}} = \mathbf{E}_0 + \mathbf{E}_1 + \frac{4\pi}{3}\mathbf{P} = \mathbf{E} + \frac{4\pi}{3}\mathbf{P}$

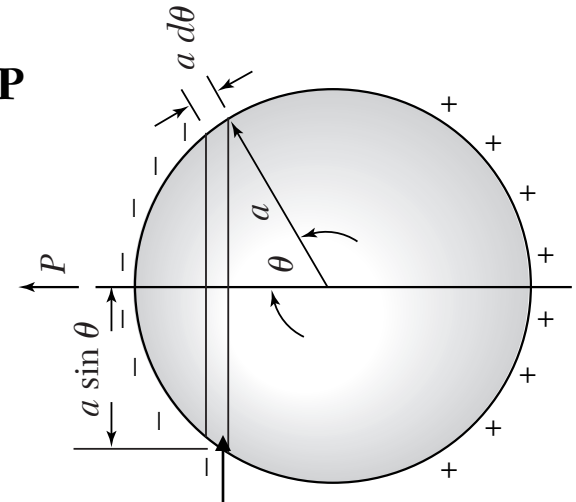

Charge on ring = $2\pi a \sin\theta \cdot a d\theta \cdot P \cos\theta$

This is the *Lorentz relation*: the field acting at an atom in a cubic site is the macroscopic field \mathbf{E} plus $4\pi\mathbf{P}/3$ from the polarization of the other atoms in the specimen.

Dielectric Constant and Polarizability

The *dielectric constant* ϵ of an isotropic or cubic medium relative to vacuum is defined in terms of the macroscopic field E :

$$\epsilon = \frac{E + 4\pi P}{E} = 1 + 4\pi\chi ; \quad \text{and} \quad \chi = \frac{P}{E} = \frac{\epsilon - 1}{4\pi}$$

The *polarizability* α of an atom is defined in terms of the local electric field at the atom: $p = \alpha E_{\text{local}}$, where p is the dipole moment. The polarizability is an atomic property, but the dielectric constant will depend on the manner in which the atoms are assembled to form a crystal. The relation of the dielectric constant to the polarizabilities depends on the relation between the macroscopic electric field and the local electric field. If the local field is given by the Lorentz relation, then the polarization of a crystal may be expressed approximately as

$$P = (\sum N_j \alpha_j) \left(E + \frac{4\pi}{3} P \right), \quad \text{and} \quad \chi = \frac{P}{E} = \frac{\sum N_j \alpha_j}{1 - \frac{4\pi}{3} \sum N_j \alpha_j} .$$

where N_j is the concentration and α_j the polarizability of atoms j .

Since $\epsilon = 1 + 4\pi\chi \quad \rightarrow \quad \frac{\epsilon - 1}{\epsilon + 2} = \frac{4\pi}{3} \sum N_j \alpha_j \quad \equiv \text{Clausius-Mossotti relation.}$

Electronic Polarizability

The total polarizability may usually be separated into three parts: electronic, ionic, and dipolar. The electronic contribution arises from the displacement of the electron shell relative to a nucleus. The ionic contribution comes from the displacement of a charged ion with respect to other ions. The dipolar polarizability arises from molecules with a permanent electric dipole moment that can change orientation in an applied electric field.

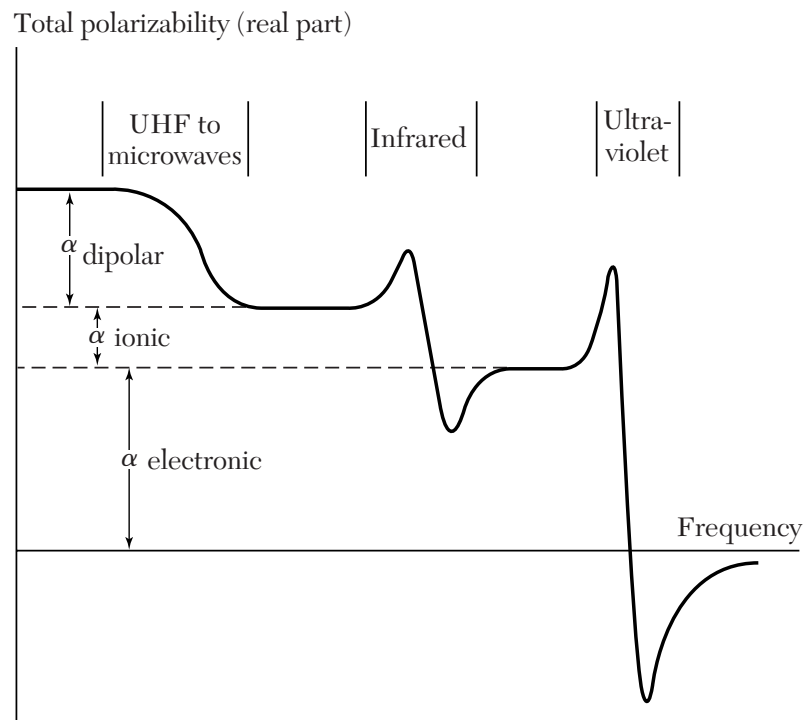

The left figure shows the frequency-dependent polarizability. The dielectric constant (ϵ) at optical frequencies arises almost entirely from the electronic polarizability. The dipolar and ionic contributions are small at high frequencies because of the inertia of the molecules and ions. In the optical range, by $\epsilon = n^2$, we obtain the refractive index n

$$\frac{n^2 - 1}{n^2 + 2} = \frac{4\pi}{3} \sum N_j \alpha_j(\text{electronic})$$

An electron bound harmonically to an atom will show resonance absorption at a frequency $\omega_0 = (\beta/m)^{1/2}$, where β is the force constant. The motion of the electron in the local electric field $E_{\text{loc}} \sin(\omega t)$ is

$$m \frac{d^2x}{dt^2} + m\omega_0^2 x = -eE_{\text{loc}} \sin \omega t$$

Let $x = x_0 \sin \omega t$, we obtain $m(-\omega^2 + \omega_0^2)x_0 = -eE_{\text{loc}}$

The dipole moment has the amplitude:

$$p_0 = -ex_0 = \frac{e^2 E_{\text{loc}}}{m(\omega_0^2 - \omega^2)} \quad \longrightarrow \quad \alpha(\text{electronic}) = \frac{e^2/m}{\omega_0^2 - \omega^2}$$

Electronic polarizabilities α of atoms and ions, in 10^{-24} cm^3

			He	Li ⁺	Be ²⁺	B ³⁺	C ⁴⁺
Pauling			0.201	0.029	0.008	0.003	0.0013
JS				0.029			
	O ²⁻	F ⁻	Ne	Na ⁺	Mg ²⁺	Al ³⁺	Si ⁴⁺
Pauling	3.88	1.04	0.390	0.179	0.094	0.052	0.0165
JS-(TKS)	(2.4)	0.858		0.290			
	S ²⁻	Cl ⁻	Ar	K ⁺	Ca ²⁺	Se ³⁺	Ti ⁴⁺
Pauling	10.2	3.66	1.62	0.83	0.47	0.286	0.185
JS-(TKS)	(5.5)	2.947		1.133	(1.1)		(0.19)
	Se ²⁻	Br ⁻	Kr	Rb ⁺	Sr ²⁺	Y ³⁺	Zr ⁴⁺
Pauling	10.5	4.77	2.46	1.40	0.86	0.55	0.37
JS-(TKS)	(7.)	4.091		1.679	(1.6)		
	Te ²⁻	I ⁻	Xe	Cs ⁺	Ba ²⁺	La ³⁺	Ce ⁴⁺
Pauling	14.0	7.10	3.99	2.42	1.55	1.04	0.73
JS-(TKS)	(9.)	6.116		2.743	(2.5)		

Three Dielectric Phases

Dielectric

polarization is,
linear

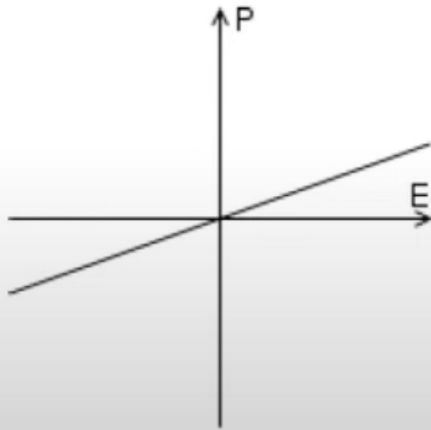

Paraelectric

nonlinear

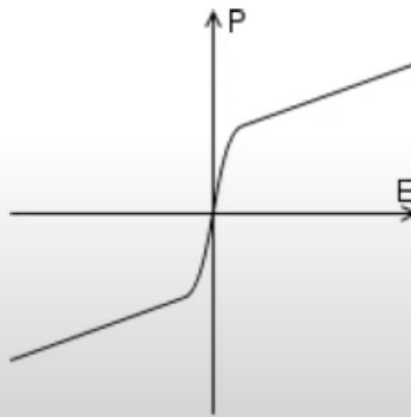

Ferroelectric

nonlinear
nonzero polarization
at $E=0$

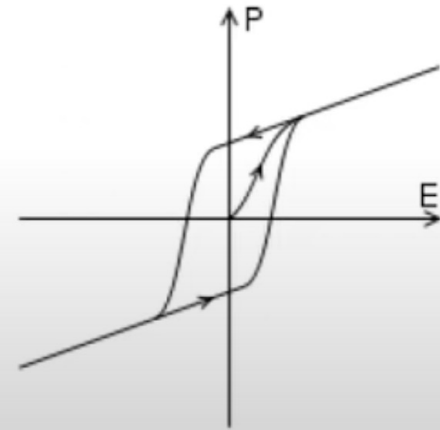

Phase Transition

- A phase is a physically distinct, chemically homogeneous and mechanically separable state.
- Change of states of matter at specific combinations of temperature and pressure is called phase transition.

First order

Latent heat is involved

Polarization is discontinuous

eg: water liquid-vapor transition

ferroelectric-paraelectric

Second order

No latent heat

Continuous variation of polarization

eg: normal-superconducting state

Ferromagnetic-paramagnetic

Structural Phase Transitions

It is not uncommon for crystals to transform from one crystal structure to another as the temperature or pressure is varied. The stable structure at a temperature T is determined by the minimum of the free energy $F = U - TS$. There will be a transition from A to B if a temperature T_c exists such that $F_A(T_c) > F_B(T_c)$. This is because the structure B may have a softer or lower frequency phonon spectrum than A . As the temperature is increased more phonons in B will be excited than the phonons in A . Because the entropy increases with the occupancy, the entropy of B will become higher than the entropy of A as the temperature is increased.

For a stable structure A at absolute zero, it generally has the lowest accessible internal energy of all the possible structures. Even this selection of a structure A can be varied with application of pressure, because a low atomic volume will favor closest-packed or even metallic structures. Hydrogen and xenon, for example, become metallic under extreme pressure.

Ferroelectric Crystals

A ferroelectric crystal exhibits an electric dipole moment even in the absence of an external electric field. In this state the center of positive charge of the crystal does not coincide with the center of negative charge. The plot of polarization versus electric field for the ferroelectric state shows a hysteresis loop.

To obtain the spontaneous polarization P_s in the CGS unit of esu cm^{-2} , multiply the value given in $\mu\text{C cm}^{-2}$ by 3×10^3 .

		T_c , in K	P_s , in $\mu\text{C cm}^{-2}$, at T K	
KDP type	KH_2PO_4	123	4.75	[96]
	KD_2PO_4	213	4.83	[180]
	RbH_2PO_4	147	5.6	[90]
	KH_2AsO_4	97	5.0	[78]
	GeTe	670	—	—
TGS type	Tri-glycine sulfate	322	2.8	[29]
	Tri-glycine selenate	295	3.2	[283]
Perovskites	BaTiO_3	408	26.0	[296]
	KNbO_3	708	30.0	[523]
	PbTiO_3	765	>50	[296]
	LiTaO_3	938	50	
	LiNbO_3	1480	71	[296]

Above the transition temperature, ferroelectricity usually disappears and the crystal is in a paraelectric state. There is usually a rapid drop in the dielectric constant as the temperature increases. In some crystals the ferroelectric dipole moment is not changed by an electric field of the maximum intensity before electrical breakdown. Such crystals are called pyroelectric. Lithium niobate, LiNbO_3 , is pyroelectric at room temperature. It has a high transition temperature ($T_c = 1480 \text{ K}$) and a high saturation polarization ($50 \mu\text{C/cm}^2$).

Character of Transition

Ferroelectric crystals may be classified into two main groups by their structural transition, order-disorder or displacive. One may define the character of the transition in terms of the dynamics of the *soft* optical phonon modes. If a soft mode can propagate in the crystal at the transition, then the transition is displacive. If the soft mode is only diffusive (non-propagating) there is really not a phonon at all, but is only a large amplitude hopping motion between the wells of the order-disorder system. Many ferroelectrics have soft modes that fall between these two extremes. The order-disorder class of ferroelectrics includes crystals with hydrogen bonds in which the motion of the protons is related to the ferroelectric properties, as in potassium dihydrogen phosphate (KH_2PO_4) and isomorphous salts. The substitution of deuterons for protons nearly doubles T_c , although the fractional change in the molecular weight of the compound is less than 2 percent:

	KH_2PO_4	KD_2PO_4	KH_2AsO_4	KD_2AsO_4
Curie temperature	123 K	213 K	97 K	162 K

Neutron diffraction data show that above the Curie temperature the proton distribution along the hydrogen bond is symmetrically elongated. Below the Curie temperature the distribution is more concentrated and asymmetric with respect to neighboring ions, giving a polarization.

Perovskite Structure

The displacive class of ferroelectrics includes ionic crystal structures closely related to the perovskite and ilmenite structures. The general chemical formula for perovskite compounds is ABX_3 , where 'A' and 'B' are two ions, often of very different sizes, and X is anion (frequently oxide) that bonds to both ions. The 'A' atoms are generally larger than the 'B' atoms. The ideal cubic structure has the B cation in 6-fold coordination, surrounded by an octahedron of anions, and the A cation in 12-fold cuboctahedral coordination. The perovskite structure of barium titanate ($BaTiO_3$) is slightly deformed below the Curie temperature, with Ba^{2+} and Ti^{4+} ions displaced relative to the O^{2-} ions, thereby developing a dipole moment. The upper and lower oxygen ions may move downward slightly.

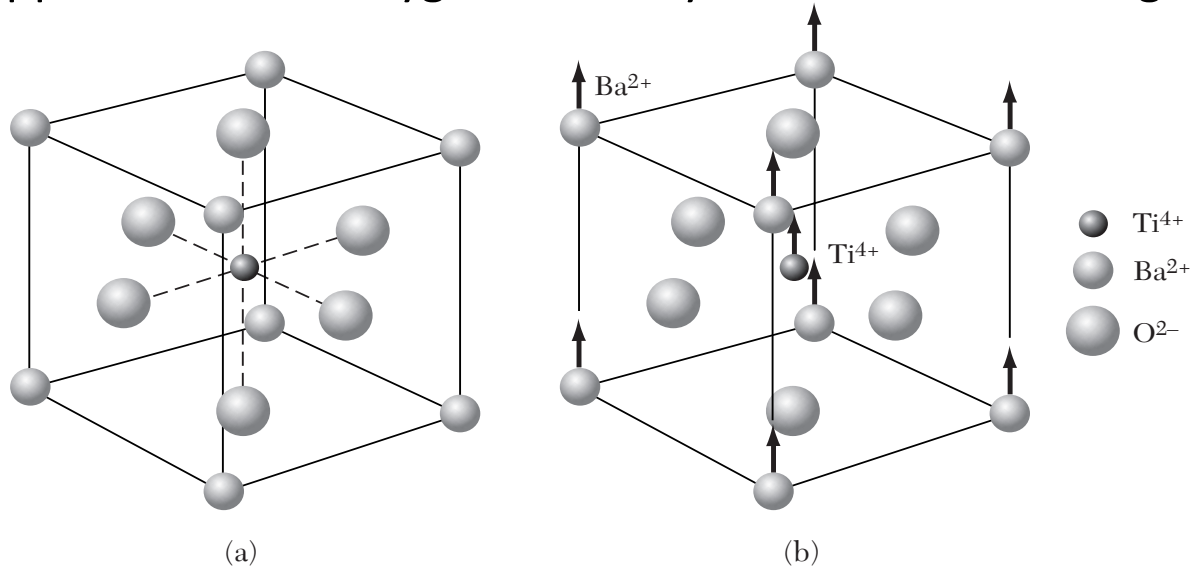

Spontaneous polarization projected on cube edge of barium titanate as a function of temperature is displayed below. Estimate the order of magnitude of the ferroelectric effects in barium titanate: the observed saturation polarization P_s at room temperature is 8×10^4 esu cm^{-2} . The volume of a cell is 64×10^{-24} cm^3 , so that the dipole moment of a cell is $p \cong (8 \times 10^4 \text{ esu cm}^{-2})(64 \times 10^{-24} \text{ cm}^{-3}) \cong 5 \times 10^{-18}$ esu cm .

If the positive ions Ba_2^+ and Ti_4^+ were moved by $\delta = 0.1$ Å with respect to the negative O_2^- ions, the dipole moment of a cell would be $6e\delta \simeq 3 \times 10^{-18}$ esu cm.

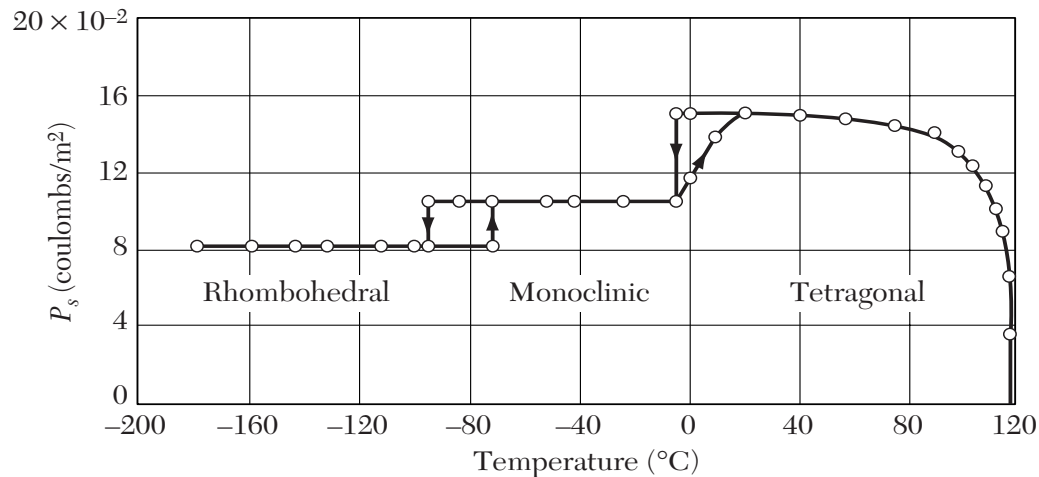
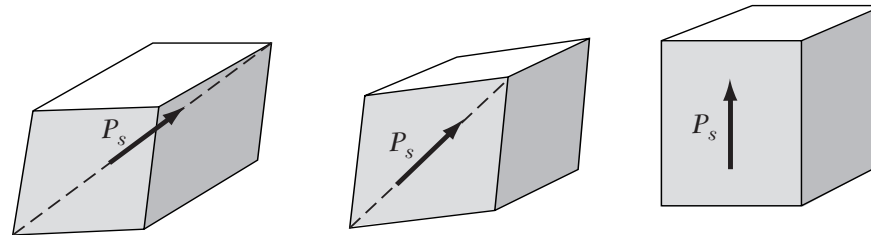

Displacive Transition

Two viewpoints contribute to an understanding of a ferroelectric displacive transition. We may speak of a *polarization catastrophe* in which for some critical condition the polarization or some Fourier component of the polarization becomes very large. Equally, we may speak of the *condensation* of a *transverse optical phonon*. This can occur when the corresponding TO phonon frequency vanishes at some point in the Brillouin zone. LO phonons always have higher frequencies than the TO phonons of the same wavevector, so need not be concerned.

The occurrence of ferroelectricity (and antiferroelectricity) in many perovskite-structure crystals suggests that this structure is favorably disposed to a displacive transition. Local field calculations make clear the reason for the favored position of this structure: the O_2^- ions do not have cubic surroundings, and the local field factors turn out to be unusually large. The dielectric constant can be rewritten in

the form
$$\epsilon = \frac{1 + \frac{8\pi}{3} \sum N_i \alpha_i}{1 - \frac{4\pi}{3} \sum N_i \alpha_i},$$
 where α_i is the electronic plus ionic polarizability of an ion of type i and N_i is the number density of ions i .

When $\sum N_i \alpha_i = 3/4\pi$, this is the condition for a *polarization catastrophe*.

If we write $(4\pi/3)\sum N_i\alpha_i = 1 - 3s$, the dielectric constant becomes $\epsilon = 1/s$, if $s \ll 1$.

Suppose near the critical temperature T_c , s varies linearly with temperature: $s = (T - T_c)/\xi$, where ξ is a constant. Then the dielectric constant has the form

$$\epsilon \simeq \frac{\xi}{T - T_c}$$

close to the observed temperature variation in the paraelectric state shown below.

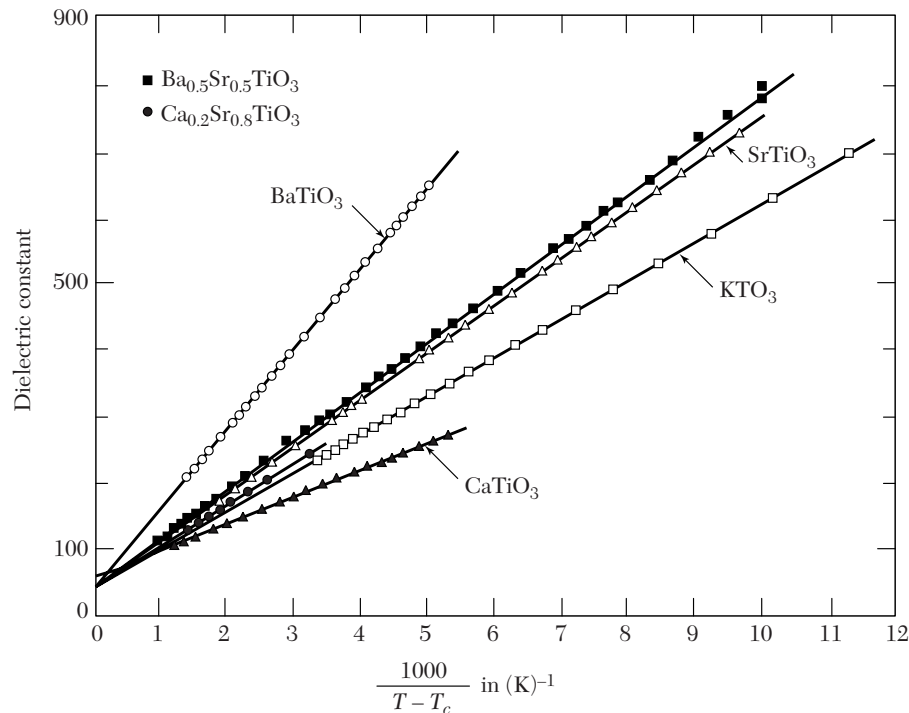

Soft Optical Phonons

According to the Lyddane-Sachs-Teller relation, $\omega_T^2/\omega_L^2 = \epsilon(\infty)/\epsilon(0)$, the static dielectric constant increases when the transverse optical phonon frequency decreases. When the static dielectric constant $\epsilon(0)$ has a high value, such as 100 to 10,000, we find that ω_T has a low value. When $\omega_T = 0$ the crystal is unstable and $\epsilon(0)$ is infinite because there is no effective restoring force.

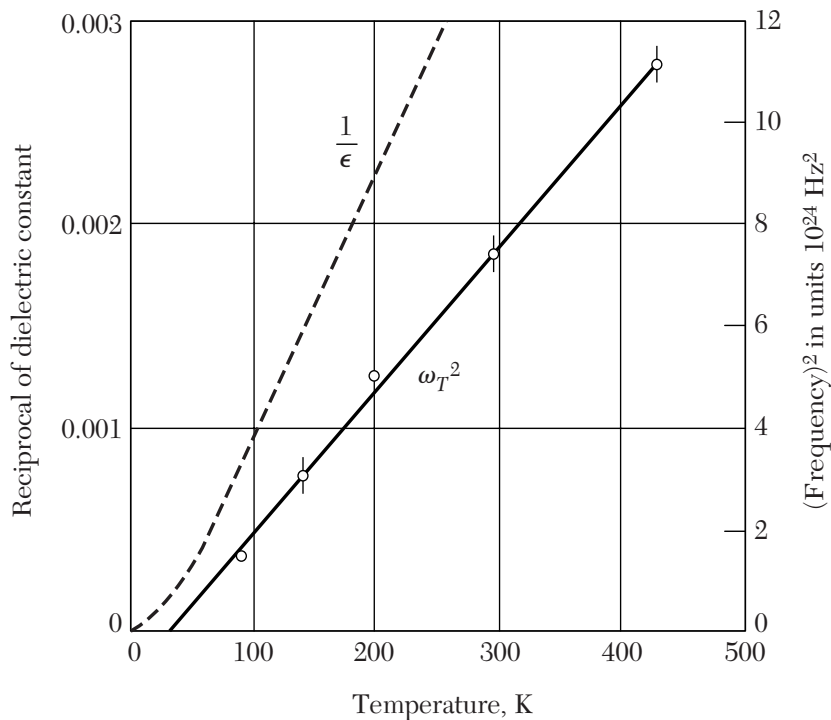

The association of a high static dielectric constant with a low-frequency optical mode is supported by experiments on strontium titanate, SrTiO_3 . According to the LST relation, if the reciprocal of the static dielectric constant has a temperature dependence $1/\epsilon(0) \propto (T - T_0)$, then the square of the optical mode frequency will have a similar temperature dependence: $\omega_T^2 \propto (T - T_0)$, if ω_L is independent of temperature.

Landau Theory of the Phase Transition

A ferroelectric with a first-order phase transition between the ferroelectric and the paraelectric state is distinguished by a discontinuous change of the saturation polarization at the transition temperature. The transition between the ferromagnetic and paramagnetic states is second-order. In this transition the degree of order goes to zero without a discontinuous change as the temperature is increased. We assume that the Landau free energy density F in one dimension may be expanded formally as

$$\hat{F}(P;T,E) = -EP + g_0 + \frac{1}{2}g_2P^2 + \frac{1}{4}g_4P^4 + \frac{1}{6}g_6P^6 + \dots ,$$

where P is the polarization of a ferroelectric crystal and the coefficients g_n depend on the temperature. The equilibrium polarization in an applied electric field E satisfies the extremum condition $\frac{\partial \hat{F}}{\partial P} = 0 = -E + g_2P + g_4P^3 + g_6P^5 + \dots$

If the specimen is a long rod with the external applied field E parallel to the long axis. To obtain a ferroelectric state we must suppose that the coefficient of the term in P^2 passes through zero at some temperature T_0 : $g_2 = \gamma(T - T_0)$, where γ is taken as a positive constant and a small positive value of g_2 means that the lattice is “soft” and is close to instability.

Second-Order Transition

If g_4 in Landau equation is positive, nothing new is added by the term in g_6 , and this may then be neglected. The polarization for zero applied electric field is found:

$$\gamma(T - T_0)P_s + g_4P_s^3 = 0$$

For $T \geq T_0$ the only real root of the above eq. is at $P_s = 0$, because γ and g_4 are positive. Thus T_0 is the Curie temperature. For $T < T_0$ the minimum of the Landau free energy in zero applied field is at $|P_s| = (\gamma/g_4)^{1/2}(T_0 - T)^{1/2}$

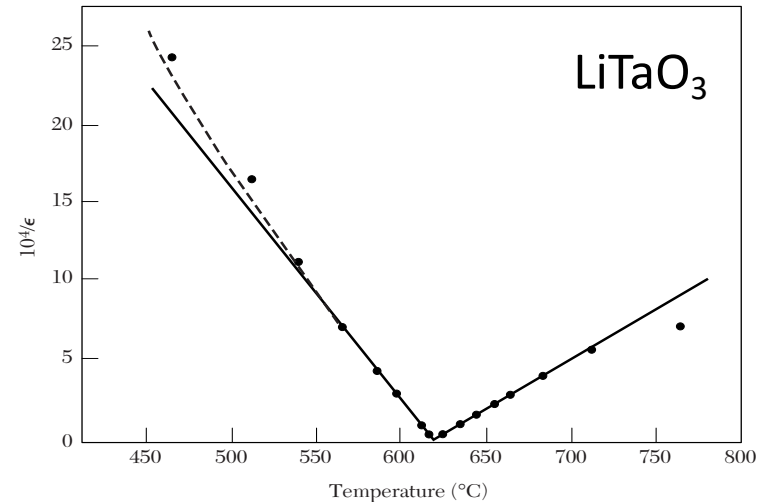
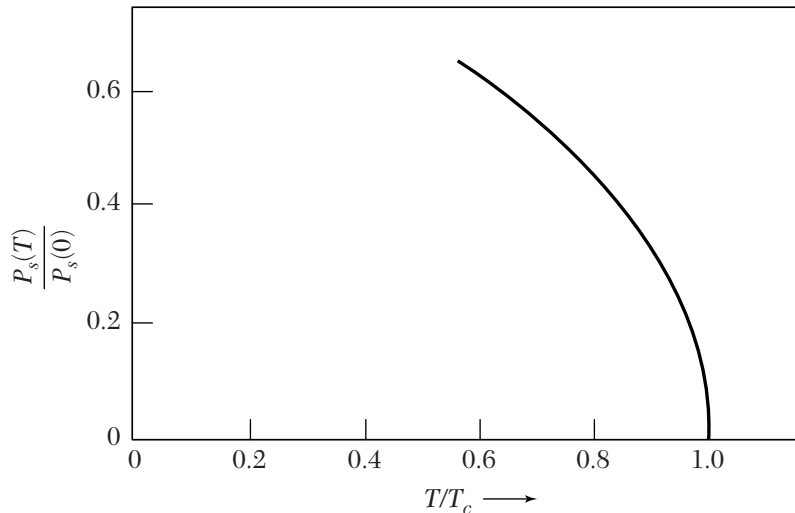

The phase transition is a second-order transition because the polarization goes continuously to zero at the transition temperature. The transition in LiTaO_3 is an example of a second-order transition.

First-Order Transition

The transition is first order if g_4 is negative. We must now retain g_6 and take it positive in order to restrain F from going to minus infinity. The equilibrium condition for $E = 0$ is given by $\gamma(T - T_0)P_s - |g_4|P_s^3 + g_6 P_s^5 = 0$

so that either $P_s = 0$ or $\gamma(T - T_0) - |g_4|P_s^2 + g_6 P_s^4 = 0$

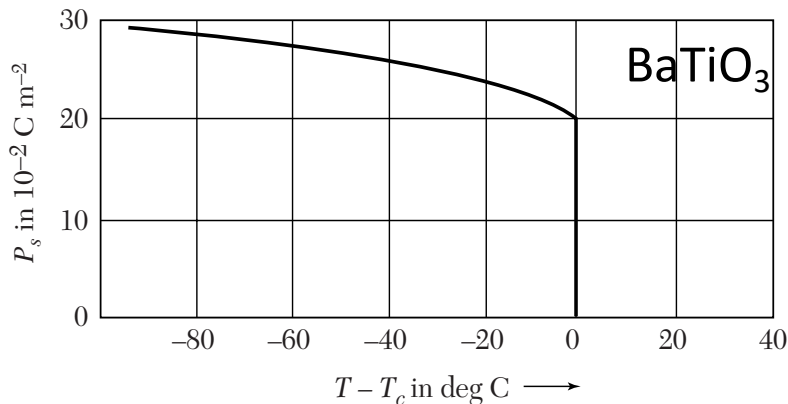

At the transition temperature T_c the free energies of the paraelectric and ferroelectric phases will be equal. That is, the value of F for $P_s=0$ will be equal to the value of F at the minimum given above.

In equilibrium at temperatures over the transition, the terms in P^4 and P^6 may be neglected; thus $E = \gamma(T - T_0)P$, or $\epsilon(T > T_c) = 1 + 4\pi P/E = 1 + 4\pi/\gamma(T - T_0)$

The result applies whether the transition is of the first or second order, but if second order we have $T_0 = T_c$; if first order, then $T_0 < T_c$. Here, T_0 is defined as the value of g_2 equals to zero and T_c is the transition temperature.

Prototypical Phase Transitions

A ferroelectric displacement is not the only type of instability that may develop in a dielectric crystal. Other deformations occur, as shown below.

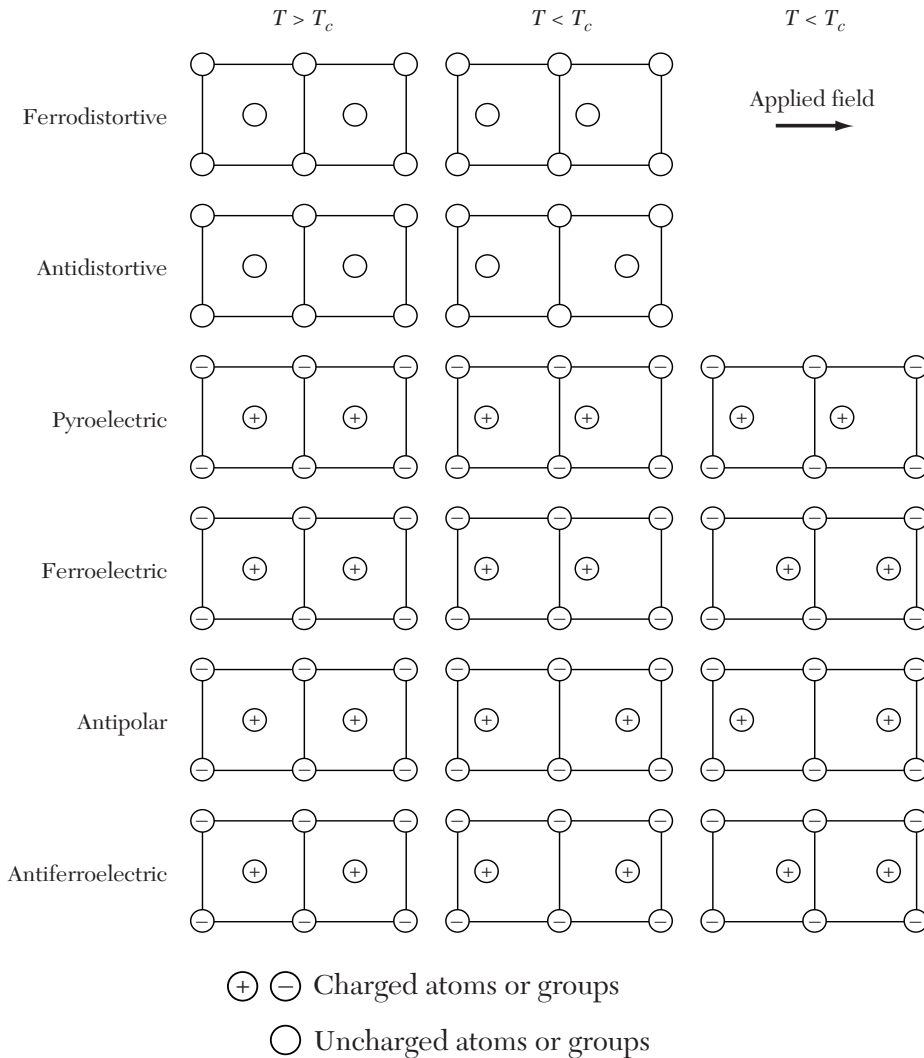

One type of deformation is called *antiferroelectric* and has neighboring lines of ions displaced in opposite senses. The perovskite structure appears to be susceptible to many types of deformation, often with little difference in energy.

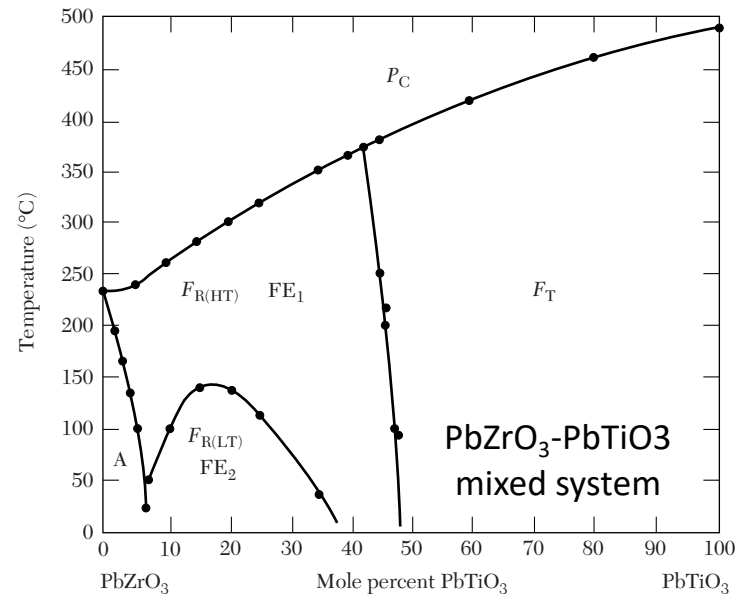

Ferroelectric Domains

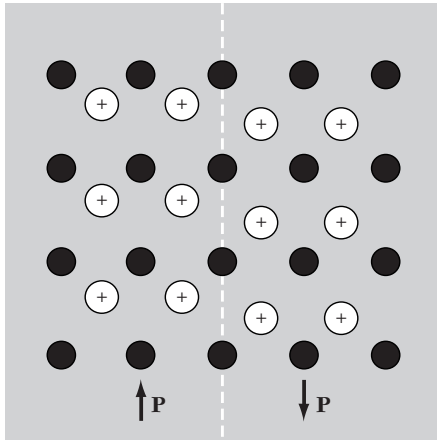

(a)

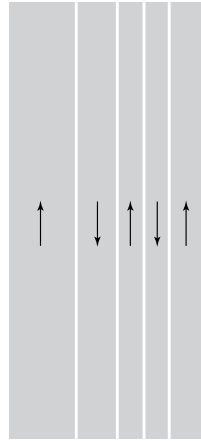

(b)

A ferroelectric crystal consists of regions called *domains* within each of which the polarization is in the same direction, but in adjacent domains the polarization is in different directions. The net polarization depends on the difference in the volumes of the upward- and downward-directed domains.

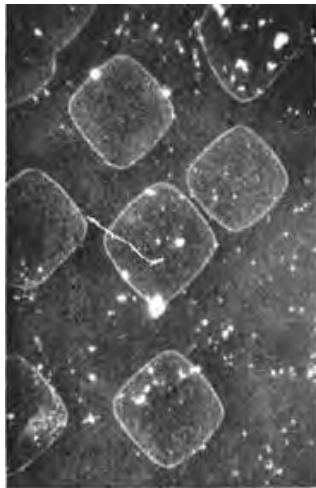

550 V/cm



705 V/cm



980 V/cm

0.01 cm

Ferroelectric domains on the face of barium titanate. The face is normal to the tetragonal or *c* axis. The net polarization of the crystal is increased markedly as the electric field intensity parallel to the axis is increased from 550 V/cm to 980 V/cm.

Piezoelectricity

All crystals in a ferroelectric state are also piezoelectric: a stress Z applied to the crystal will change the electric polarization. Similarly, an electric field E applied to the crystal will cause the crystal to become strained. In schematic one-dimensional notation, the piezoelectric equations are

$$P = Zd + E\chi; \quad e = Zs + Ed$$

where P is the polarization, Z the stress, d the *piezoelectric strain constant*, E the electric field, χ the dielectric susceptibility, e the elastic strain, and s the elastic compliance constant.

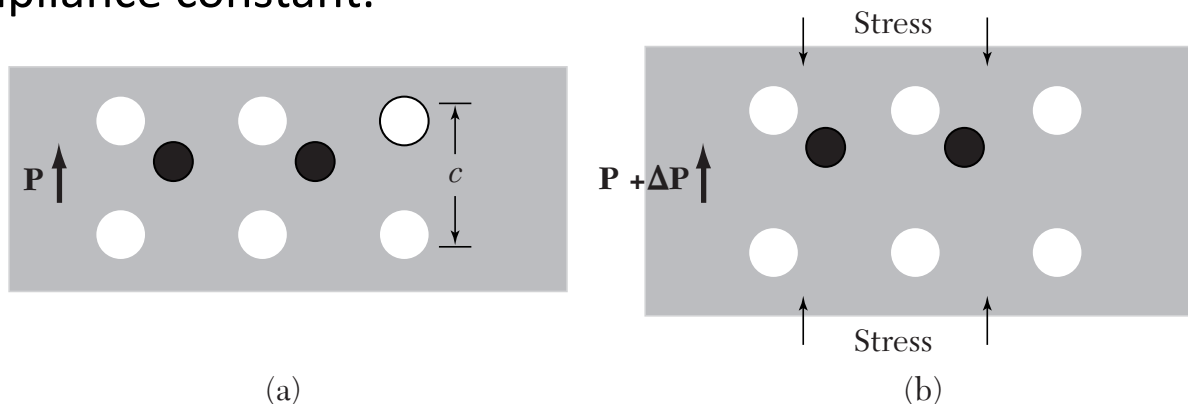

The general definition of the piezoelectric strain constants is $d_{ik} = (\partial e_k / \partial E_i)_Z$ where $i \equiv x, y, z$ and $k \equiv xx, yy, zz, yz, zx, xy$. To convert to cm/stat-V from values of d_{ik} given in m/V, multiply by 3×10^4 .

A crystal may be piezoelectric without being ferroelectric: a schematic example of such a structure is illustrated below. Quartz is piezoelectric, but not ferroelectric; barium titanate is both. For order of magnitude, in quartz $d \simeq 10^{-7}$ cm/statvolt and in barium titanate $d \simeq 10^{-5}$ cm/statvolt.

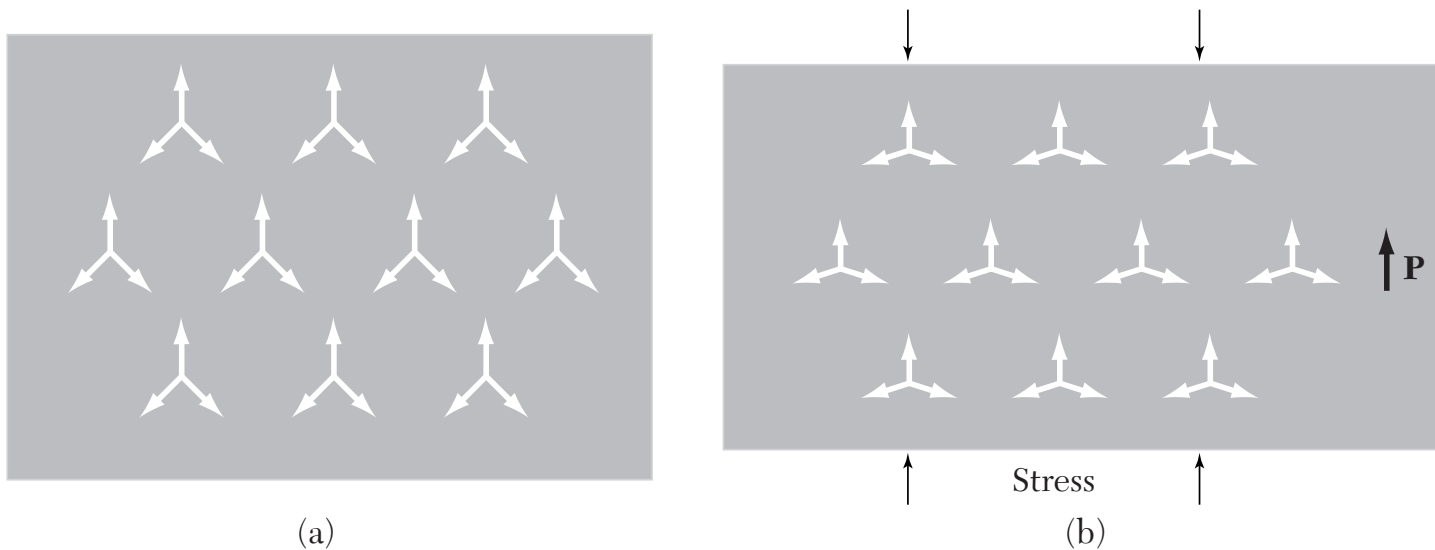

The lead zirconate-lead titanate system (called the PZT system) is widely used in polycrystalline (ceramic) form with compositions of very high piezoelectric coupling. The synthetic polymer poly-vinylidene fluoride (PVF_2) is five times more strongly piezoelectric than crystalline quartz. Thin stretched films of PVF_2 are flexible and as ultrasonic transducers are applied in medicine to monitor blood pressure and respiration.

Piezoelectric Response

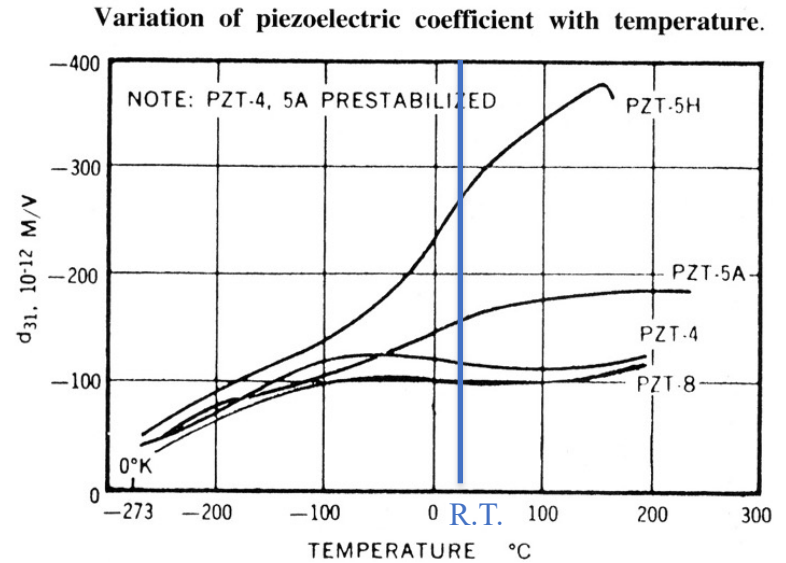
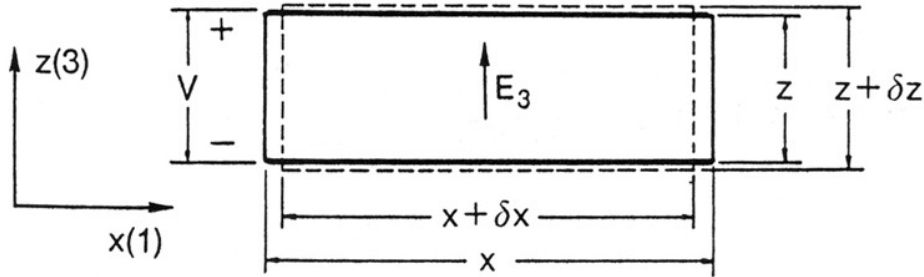

Strain: $S_1 = \delta x/x$, $S_3 = \delta z/z$

Electric field: $E_3 = V/z$

Piezoelectric Coeff.: $d_{33} = S_3/E_3$, $d_{31} = S_1/E_3$

Typical values for $d_{31} \sim -1 \text{ \AA/V}$, $d_{33} \sim 3 \text{ \AA/V}$.

Inchworm Motor

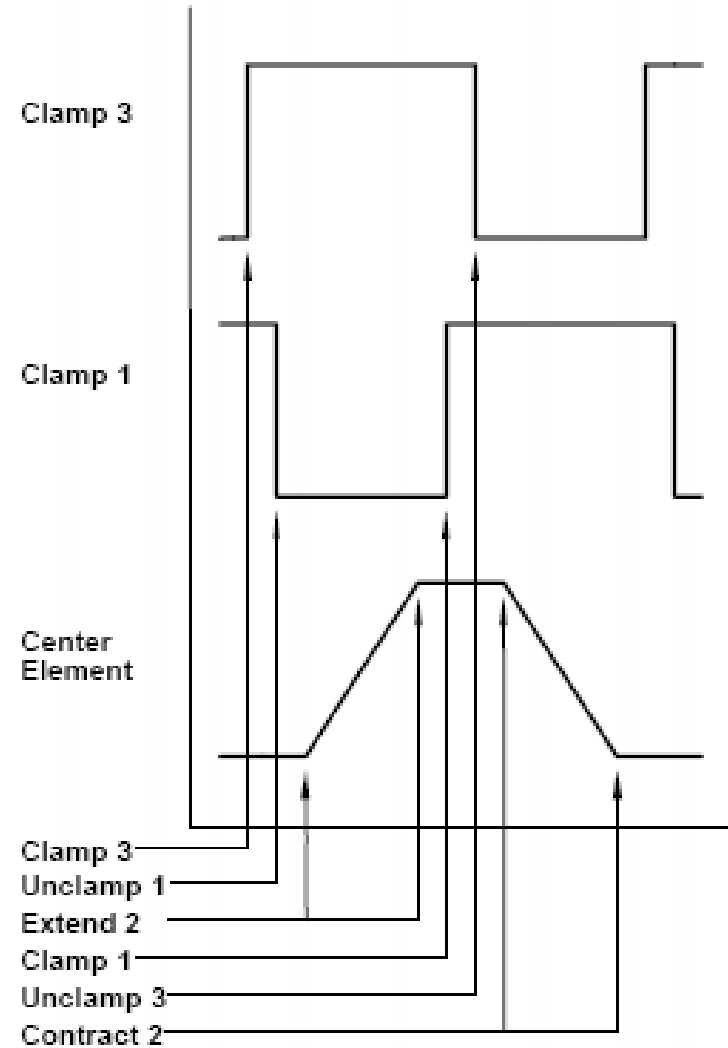
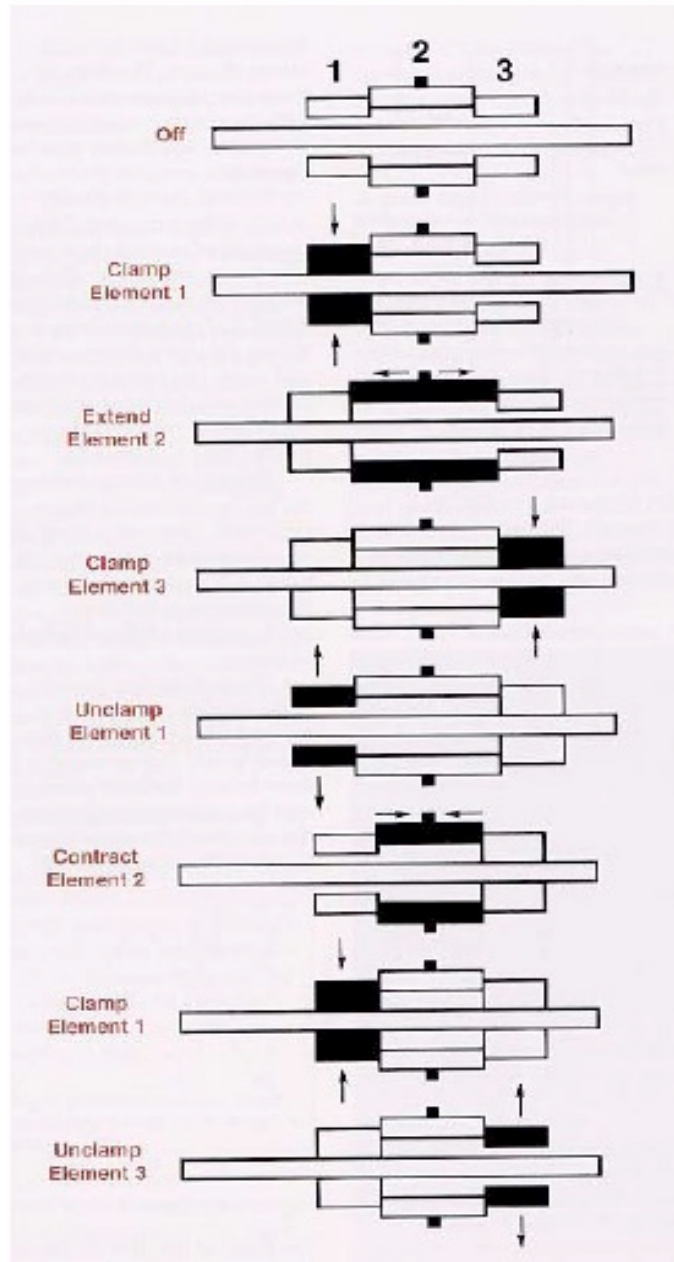

Piezoelectric Scanner

Tripod scanner

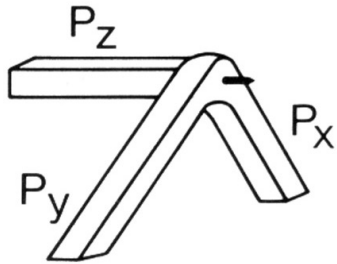

$$S_1 = \delta x/x = d_{31}E_3 = d_{31}V/z$$

Piezoelectric Constant:

$$K = dx/dV = d_{31}L/h$$

Resonance Freq. for bending:

$$f = 0.56 \kappa C/L^2, \kappa = h/\sqrt{12}$$

Tube scanner

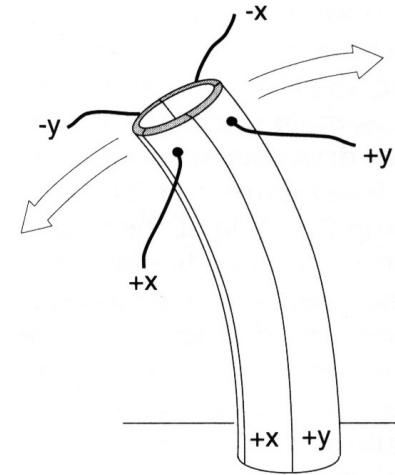

Piezoelectric Constant:

$$K = dx/dV = 2\sqrt{2}d_{31}L^2/\pi Dh$$

Resonance Freq. for bending:

$$f = 0.56 \kappa C/L^2, \kappa = (D^2 + d^2)^{1/2}/8$$

Problems

- 1. Polarizability of conducting sphere.** Show that the polarizability of a conducting metallic sphere of radius a is $\alpha = a^3$. This result is most easily obtained by noting that $E = 0$ inside the sphere and then using the depolarization factor $4\pi/3$ for a sphere. The result gives values of α of the order of magnitude of the observed polarizabilities of atoms. A lattice of N conducting spheres per unit volume has dielectric constant $\epsilon = 1 + 4\pi N\alpha^3$, for $Na \ll 1$. The suggested proportionality of α to the cube of the ionic radius is satisfied quite well for alkali and halogen ions.
- 2. Dielectric constant below transition temperature.** In terms of the parameters in the Landau free energy expansion, show that for a second-order phase transition the dielectric constant below the transition temperature is
$$\epsilon = 1 + 4\pi\Delta P/E = 1 + 2\pi/\gamma(T_c - T) .$$

3. *Soft modes and lattice transformations.* Sketch a monatomic linear lattice of lattice constant a . (a) Add to each of six atoms a vector to indicate the direction of the displacement at a given time caused by a longitudinal phonon with wavevector at the zone boundary. (b) Sketch the crystal structure that results if this zone boundary phonon becomes unstable ($\omega \rightarrow 0$) as the crystal is cooled through T_c . (c) Sketch on one graph the essential aspects of the longitudinal phonon dispersion relation for the monatomic lattice at T well above T_c and at $T = T_c$. Add to the graph the same information for phonons in the new structure at T well below T_c .